

SPECIFICATION

1. PHYSICAL DIMENSION(UNIT: m/m):

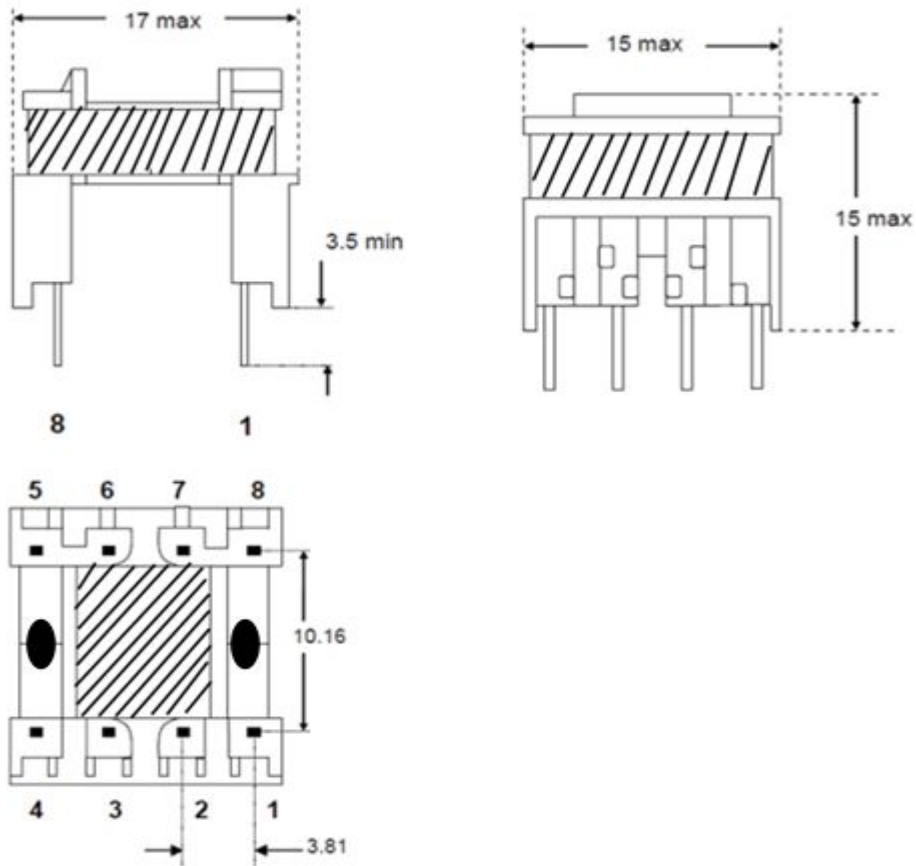

※DIMENSIONS WITHOUT TOLERANCE ARE APPROX
 ※DIMENSION DOES NOT INCLUDE SOLDER USED ONCOILS

LEAD FREE

DIM	A	B	C	D	E	F	G	H				
SPEC												
						DESCRIPTION			TRANSFORMER			
						Customer P/N						
						FERRIWO P/N			FWPTEF12.6H262L			
SPEC. NO.	PS-1001-004				PREPARED				APPROVED			

SPECIFICATION

2.WINDING TABLE:

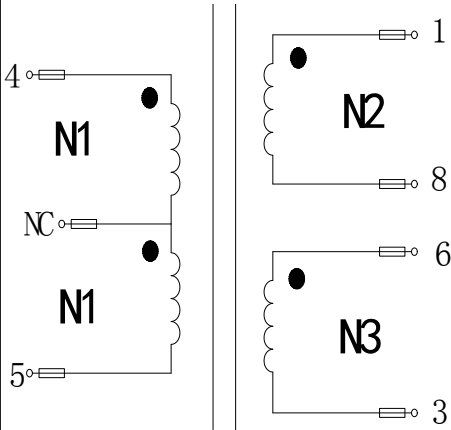

3.WINDING:

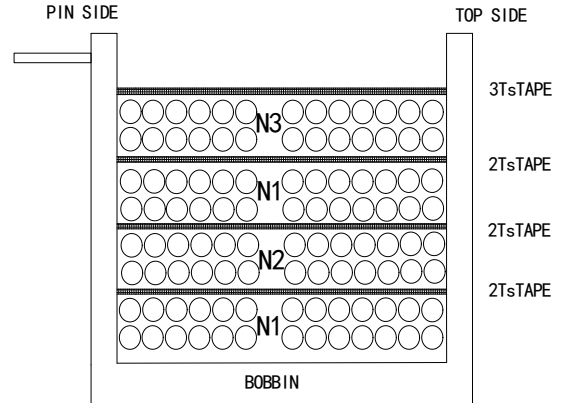

4.WINDING TABLE:

Winding NO.	Margin Tape	PIN	Wire &Wire Copper	Turns	Winding Type	Tape Layer	Tube
N1	0	4~NC			Compact	2	F=7mm S=12mm
N2	0	1~8			Compact	2	F=S=10mm
N1	0	NC~5			Compact	2	S=7mm
N3	0	6~3			Compact	3	F=S=10mm

NOTE:

- Products should be vacuum impregnation
 - *VARNISH RATIO: 1:1
 - *VACUUM TIME: 15~20minutes
 - *BAKED TEMPERATURE : 120°C±10°C, 1~1.5hours

LEAD FREE

	DESCRIPTION	TRANSFORMER	
	Customer P/N		
	FERRIWO P/N	FWPTEF12.6H262L	
SPEC. NO.	PS-1001-004	PREPARED	APPROVED

SPECIFICATION

5. ELECTRONICAL CHARACTERISTIC:

TEST CONDITION : TEMPERATURE AT 25°C

HUMIDITY AT 65 ±5% RH

TEST ITEM	TEST CONDITION	RESULT
INDUCTANCE CH-3250	@100KHz,1V (4~5)	2.6mH±13%
LEAKAGE INDUCTANCE CH-3250	@100KHz,1V (4~5)	70.0μH MAX SHORT PIN 1,8
	@100KHz,1V (6~3)	7.0μH MAX SHORT PIN 1,8
HI-POT TEST CH-9052	@ 2mA 3SEC (AC)	P<->S 3.0 KV; S<-> CORE 3.0 KV;

LEAD FREE

FERRIWO

DESCRIPTION

TRANSFORMER

Customer P/N

FERRIWO P/N

FWPTEF12.6H262L

SPEC. NO.

PS-1001-004

PREPARED

APPROVED

SPECIFICATION

6. MATERIAL LIST :

ITEM		MATERIAL	SUPPLIER OR MANUFACTURER	TEMPRATING
1	CORE	FW40 OR EQUIVALENT	HAINING FERRIWO ELECTRONICS CO., LTD.	
2	BOBBIN	PHENOLIC OR EQUIVALENT	SUMITOMO BAKELITE CO., LTD. UL NO E41429	150℃
3	WIRE	UEW	PACIFIC ELECTRIC WIRE&CABLE(SHENZHEN) CO. LTD UL NO E84081	130℃
4	TRIPLE WIRE	TRIPLE. INSULATION. WIRE TRW(B)	GREAT LEOFLON INDUSTRIAL CO.,LTD UL NO E211989	130℃
5	TAPE	CT280	YAHUA STICKING TAPE CO.,LTD UL NO E165111	130℃
6	TUBE	TEFLON TUBE	GREAT HOLDING INDUSTRIAL CO.,LTD UL NO E156256	200℃
7	VARNISH	R-1038	JOHN C DOLPH CO BC-346A UL NO E317427	130℃
8	FLUX	TF9100	LINAN GUITONG CHEMICAL TECHNICAL CO.,LTD	
9	TIN	Sn99.3Cu0.7	HAINING ZHUCHANG METAL FOIL CO;LTD	
10	EPOXY	E-500 (BLACK)	SUZHOU EATTO ELECTRONIC MATERIAL CO.,LTD UL NO E218090	130℃

LEAD FREE



DESCRIPTION

TRANSFORMER

Customer P/N

FERRIWO P/N

FWPTEF12.6H262L

SPEC. NO.

PS-1001-004

PREPARED

APPROVED